

PISTON VALVES

Klinger KVN
DN10-50

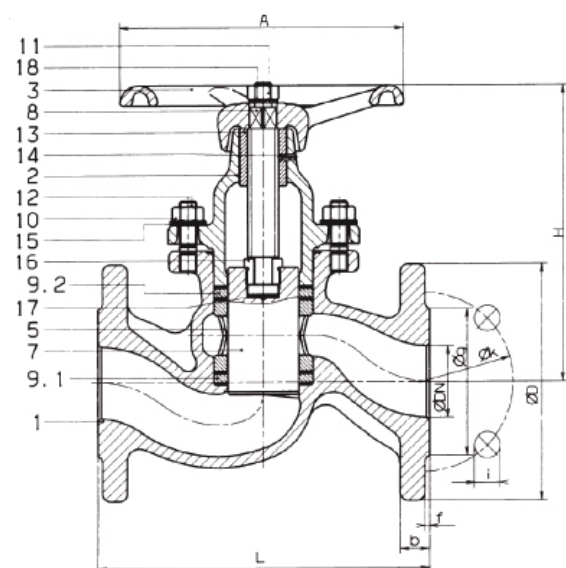

PARTS

No.	Part	Material		
		III / GG25	VIII / GS-C35	Xc / 1.4581
1	Body	GG-25	GG-25	1.4581
2	Bonnet	GG-25	GS-C25	14581
3	Handwheel	GG-20		
4	Lantern bush	Sint-C 10		1.4401
7	Piston	1.4104		1.4401
8	Stem	95Mn28K		1.4401
9.1	Upper valve ring	KX-graphite		
9.2	Lower valve ring	KX-graphite		
10	Bonnet nut	5		A4
11	Handwheel nut	5		A4
12	Bonnet bolt	1.1181		A4
13	Split nut	-	Sint-C11 spec. ¹⁾	1.4404 ¹⁾
14	Tension pin	-	Spring steel	1.4305 ¹⁾
15	Disc spring	50CrV4		1.4122
16	Spindle securing nut	9SMn28K+N chem. Ni5-6		1.4571
17	Disc	90MnCrV8 hard cald		1.4571 hard clad
18	Serrated lock washer	Spring steel		

KLINGER-CODE:

III	Cast steel	PN16	With flanges
VII	Steel	PN40	With flanges
XC	Acid resistant steel	PN40	With flanges
XC	Factory dimensioning		

¹⁾ Only DN 40 ja DN 50

DIMENSIONS AND WEIGHTS

DN	L	H	Isku	A	kg	
					PN16 III	PN40 VIII/XC
10	130	105	23	100		2,50
15	130	105	23	100	2,50	2,70
20	150	102	28	120	4,15	4,60
25	160	139	33	140	5,40	5,90
32	180	156	37	160	8,50	9,10
40	200	186	44	180	10,90	11,40
50	230	211	51	200	14,20	16,30

PRESSURE/TEMPERATURE (bar)

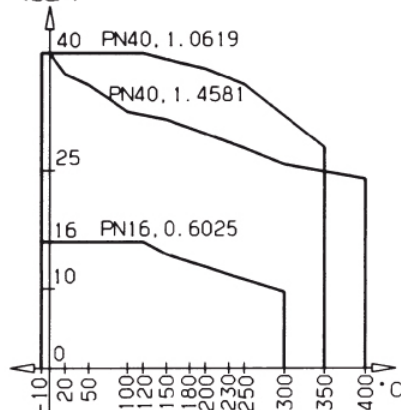

OPTIONS

- » With ANSI flanges
- » adjustable piston

ALSO FOR LIQUIFIED GASES

Part 4	1.4541/1.4408
Part 8	1.4305
Part 9,1	KFG
Part 9,2	KFG